

# FABORY

---

Supplier Manual

Version 2.1

February 2024

---



[www.fabory.com](http://www.fabory.com)

## Table of contents

1. Introduction.....	3
2. Purchasing .....	4
2.1 Communication .....	4
2.2 Quotation process.....	4
2.3 Order placement .....	5
2.4 Order confirmation .....	6
2.5 Advanced shipping notice (ASN) .....	6
2.6 Invoicing .....	6
2.7 Supplier Performance Rate (SPR).....	6
3. Quality .....	7
3.1 General principles .....	7
3.2 Minimum Quality management system requirements.....	7
3.3 Minimum Product Quality requirements .....	7
3.4 Product Quality Documents/Certificates .....	7
3.5 Product Quality Complaints and Rejections.....	7
3.6 Batch traceability .....	8
3.7 Audits by Fabory .....	8
4. Inbound logistics.....	9
4.1 Sell packs .....	9
4.2 Master pack.....	10
4.3 Pallet .....	11
5. Transport .....	13
5.1 Physical delivery of goods .....	13
5.2 Preferential incoterms .....	13
5.3 Collaboration guidelines .....	13
5.4 Additional sea freight requirements .....	14
6. Compliance and ESH .....	15
6.1 General principles .....	15
6.2 Anti-corruption.....	15
6.3 Principles of human rights and social justice .....	15
6.4 Health and safety .....	16
6.5 Environment.....	16
6.6 Material compliance & conflict minerals .....	16
6.7 Auditing & reporting .....	17
Appendices .....	18

## 1. Introduction

At Fabory, we see Suppliers as direct extension of our company. Our success is built on strong, successful relationships and the ability to build responsible and fair business practices across our supply chain based on close, long-term relationships with our customers, suppliers, and other business partners.

With this Supplier Manual, we like to help you as Supplier to meet Fabory's inbound supply chain requirements to ensure and maintain a successful and professional relationship. Meeting the requirements in this manual adds value to our joint Supply Chains by making communication and handling more efficient. The latest version of the Supplier Manual can be found on <https://www.fabory.com/nl/group/suppliers>.

Together with you we expect to deliver perfect operational performance and continuously improve operations, especially concerning the high quality of materials or services provided, on-time delivery, and completeness and correctness of the documentation. Please be proactive in your communication and react to any unexpected changes before Fabory becomes aware of them.

Fabory aims to maintain high standards of ethical and business conduct within its operations and extend these best practices to our business partners. We expect you to follow Fabory's expectations regarding social responsible business operations.

## 2. Purchasing

Fabory values true partnership and collaboration. Fabory has a strong preference for Electronic Data Interchange (EDI) as it improves the quality of the interaction between Fabory and you. It reduces transaction costs on both sides and reduces errors. EDI transforms your customer interaction into simplified and digitalized supply chain activities. Electronic ordering allows scalable and efficient processes while reducing costs.

### 2.1 Communication

Communicating with Fabory can be done using one of the options below.

- Ariba DSN: this is a platform that allows you to digitalize the ordering process and connecting not only to Fabory but to a set of other customers as well. There are three different ways to use the platform.
  1. The ERP connection has the benefit of connecting your ERP system to Ariba. It is comparable to a direct EDI connection, with the additional benefit of connecting to multiple customers at once. This variant will be the best solution when you expect to place hundred or more POs per week, either with us or other customers
  2. The cxml option allows you to send your ERP outputs with a cxml upload to the platform, simplifying the process of uploading documents. This solution is the best when you expect between five to a hundred POs per week
  3. The web tool is the lowest form of integration. You can still process all documents and this solution is the best when you expect no more than five POs weekly

The standard account is free of charge, this is depending on transacting volume and account type. All message types Fabory is supporting are included in the standard account. For more information please refer to this link. [Ariba DSN/SAP Business Network](#)

- Classic EDI: this entails a direct connection with Fabory's ERP. This solution is preferred by our most important suppliers. Fabory's preferred message format is EDIFACT97A and communication method AS2.

Fabory currently supports four EDI message types.

- EDI order (ORDERS): a Purchase Order format sent by Fabory, asking for goods or services order similar to a conventional order
- EDI order confirmation (ORDRSP): sent by the supplier used to accept or reject the order sent by Fabory
- EDI advance shipment notification (DESADV): sent by the supplier to signal the dispatch and detailed contents of the shipment. The message has to be sent out immediately with GI booking to ensure it is received before the arrival of the goods at our facility.
- EDI invoice (INVOIC): sent by the supplier to claim the payment for the goods sent.

If you have questions on digital interaction, then you can reach out to your responsible procurement contact.

A short conversion period can be agreed, as long as E-Mail attachments are used. To be able to convert these PDFs on our end it is mandatory that the PDF is not a scanned paper document but a system generated OpenPDF. The supplier name or logo should be visible. This is only possible for an agreed transition period towards Ariba or Classic EDI.

### 2.2 Quotation process

The supplier will receive request for a quotation by email. When responding to a request for quote (RfQ), Fabory requires the following information to be listed to be considered:

- |   |                                       |
|---|---------------------------------------|
| - Price per 1 pc. 100 pcs or 1.000 pcs            | - Payment terms (similar to RfQ)      |
| - Note any exceptions to the print/specifications | - Incoterms (similar to RfQ)          |
| - Weight in kilo per 100 or 1,000 pcs             | - Fabory and manufacturer part number |
| - Country of Origin                               | - Supplier item description           |
| - Minimum Order Quantity                          | - Box quantity                        |
|   | - HTS code                            |

Tooling, certification and quality costs must be itemized separately instead of amortized into the piece parts price.

Every request for a quote will include a timeline to which the supplier must adhere. Quotes will only be considered in Fabory's offering to the customer when received before the noted deadline. Suppliers are required to respond with one of the following, quote exact part, quote part with exception(s), or no quote.

The lead time for parts should be clearly stated on the supplier's quotation according to the agreed terms of delivery. If DDP or DAP transit time is to be included.

Quotation deadline date: 08.03.2023		<b>Req. for quotation</b>					
Terms of delivery :		Collective Nr :	BB070323				
Terms of payment :		RFQ number :	<b>6001085272</b>				
Supplier Nr :		Document date :	07.03.2023				
Contact name :		Name of Purchaser :	010 B. Blaschke				
Your reference :		Telephone number :	+31612151355				
Document date :		Email address :	bjorn.blaschke@fabory.com				
<b>Please inform us on your best price and time of delivery for the following item(s) by returning this document.</b>							
Item	Article nr.	Description	Qty Packing	Requested Del. date	Price	Per	Leadtime
10	07141.050.045	M5X45 I7380-2 010.9 ZPL HEX SKT BTT HD FLG SCR RoHS compliance ZN COLORLESS PASSIV. 5MU Lotnum on every packing required! (0150)	3.800 EA 200 EA	10.05.2023			xxx euro / 100pcs  xxx weeks from order
	Cert.type:						
20	07450.080.040	M8X40 I10642 08.8 ZIPL CSK SCK SCR HEXALOBULAR RoHS compliance ZN COLORLESS PASSIV. 5MU Lotnum on every packing required! (0150)	4.000 EA 100 EA	09.03.2023			xxx euro / 100pcs  xxx weeks from order
	Cert.type:						

## 2.3 Order placement

Our EDI interaction will start with an EDI order. In the transition period to EDI, you will receive your purchase order via email. Product label details are sent over after order placement.

<b>Delivery address</b> Central Warehouse Fabory Simon De Cockstraat 21 5048 AW TILBURG NETHERLANDS		<b>Purchase order</b>				
Terms of delivery :		Order number :	<b>3462910</b>			
Terms of payment :		Document date :	06.03.2023			
Supplier Nr :		Name of Purchaser :	010 R. Gregus			
Contact name :		Telephone number :				
Your reference :		Fax number :				
Delivery date :		Email address :	radoslav.gregus@fabory.com			
Departure date :						
Quotation :						
Quotation date :						
Item	Article nr.	Description	Qty Packing	Price EUR	Disc./ Per Surch.	Nett
20	01236.080.080	M8X80 I4017(D933) 8.8 FLZNNC-NC6-HEX CAP SCREW RoHS compliance ZINCFLAKE ISO10683 FLZNNC	2.400 EA 200 EA		100	
	Delivery date:	17.03.2023				
	Departure date:	10.03.2023				

The departure date is the date the goods should leave your warehouse. The delivery date is the date the goods should arrive at our warehouse.

## 2.4 Order confirmation

The second EDI interaction is the order confirmation. Orders must be confirmed within two days of receiving our purchase order. When EDI is not connected yet the order confirmation can be sent to the e-mail address mentioned in the PO header. Please refer to the example below.

Supplier letter head with address details, phone/fax/email										
								Page: -----		
SALES CONTRACT										
MESSRS		: FABORY GROUP				Date		:		
ADDR		: PO BOX 5034				PO NO:		:		
		: 5004 EA TILBURG, THE NETHERLANDS				SC/NO:		:		
KIND ATTENTION :					SHIPMENT TERMS:					
FAX NO :					PACKING TYPE:					
TELEPHONE NO :										
TERM OF PAYMENT:										
NO	DESCRIPTION	CUSTOMER PART NO	Cargo ready Date	PCS/CTN(MPCS	PCS/BOX(MPCS	QTY(MPCS)	CTNS	PRICE(EUR)	AMOUNT(EUR)	
**DIN 912HEX SOCKET HEAD BOLT FULL THRD ZINC-BLUE H.T. (8.8)**										
(001)	M8 X 20	07160.080.020	05-JUN-2023	1.800	0.200	504.000	280			
**DIN 933 HEX HD BOLT FULL THRD PLAIN H.T. (8.8)**										
(002)	M8 X 55	01010.080.055	05-JUN-2023	0.800	0.200	16.000	20			

If supplier has its own Sales Confirmation format, at least the following information must be mentioned:

- Fabory part number
- Manufacturer part number
- Box quantity
- Supplier item description
- Item weight
- HTS code

## 2.5 Advanced shipping notice (ASN)

The third EDI interaction is the ASN sent out to signal the dispatch and detailed contents of the shipment. The message has to be sent out immediately with GI booking to ensure it stands received before the arrival of the goods at our facility. Upon arrival, the pallet labelled with a barcode is scanned and linked to your shipment contents. Pending EDI connection the PDF ASN should be sent to [cwtinboundadministratie@fabory.com](mailto:cwtinboundadministratie@fabory.com).

## 2.6 Invoicing

The final EDI interaction is the EDI invoice. During the transition to EDI the PDF invoices should contain at least a reference to our purchase order and PO line item. A table of E-mail addresses for E-invoices can be found in Appendix A. For intercontinental shipments a separate shipping and down payment process applies which can be found in Appendix B.

## 2.7 Supplier Performance Rate (SPR)

Fabory evaluates all the suppliers SPR scores based on the performance in the past 12 months. The adherence of Fabory suppliers to this Supplier Manual is measured and evaluated on a structural basis. Material quality and compliance, logistic service and on-time delivery are taken into account. A high SPR is a condition for doing business with Fabory. Simultaneously a supplier with a lower SPR will likely be awarded a lower business share. Details on your SPR can be provided by your Fabory procurement department contact.

## 3. Quality

### 3.1 General principles

Unless otherwise specified, delivered goods must comply to the latest edition of the applicable standards and specifications mentioned in the purchase order. Product standards generally refer to other standards with requirements that are also applicable for the described product. These references are also to be applied according to the latest edition unless other written agreement with Fabory.

It is the Supplier's responsibility to obtain and apply the latest edition of applicable standards. It is Fabory's responsibility to provide the latest edition of non-standard specifications such as a customer drawing. Supplier must contact Fabory if any reference specification of a drawing is not available.

Fabory can require in its PO or in a Quality Agreement with the Supplier to comply to more stringent quality requirements than described in this Supplier Manual.

Supplier shall cooperate with Fabory with the attitude to continuously improve on his quality performance.

### 3.2 Minimum Quality management system requirements

Supplier shall maintain a certified quality management system according to ISO 9001 as a minimum. All production facilities used for the delivered goods must be within the scope of certification. Subcontractors for raw materials, heat treatment and coating shall also be ISO 9001 certified.

A Fabory purchase order might require more stringent quality management systems, e.g. certification to IATF 16949, EN 15048-1, EN 14399-1, PED, ADW etc.. In this case the supplier shall organize that the delivered goods are produced in the production plants that are in the scope of such certification and that the procedures that apply to this certification have been applied for the production and quality control of the delivered batches.

### 3.3 Minimum Product Quality requirements

The supplier is responsible to deliver goods that are fully in compliance to each detail of the specification and the referred specifications, also if not each of the specified characteristics is required to be tested.

The supplier will target to supply close to zero defect (0 ppm = zero defect parts per million). For standardized fasteners and for fasteners produced according customer specification or according a branded specification, the quality level of the delivered batches must comply with ISO 3269 – latest edition.

### 3.4 Product Quality Documents/Certificates

Supplier shall assure that product quality inspection certificates and related quality documents have a clear match with the delivered batch of products and will contain the lot number mentioned on the packaging, batch number of raw material, product markings, product specification.

If the Fabory PO requires certificates type 3.1, this is according to EN 10204. For fasteners the minimum contents for quality inspection certificates must comply to the certification requirements and inspection test results of the applied material specification, to EN 10204 and to ISO 16228 type F3.1.

In case of repeating purchase orders for PPAP Level 3 articles, Supplier is obliged to inform and receive agreement from Fabory on any change related to the production or quality control of these articles, for example for usage of other base material type, change in production location or machine/tool type, changed inspection plans, etc.

The certificates and other Quality documents must (also) be sent by e-mail in PDF format. The e-mail with the PDF must mention the PO number for which the PDF is applicable.

### 3.5 Product Quality Complaints and Rejections

Product Quality Complaints and Rejections must be handled by the Supplier with high priority to avoid stock disruptions at Fabory or production disruptions at Fabory's customers. Supplier shall apply predefined methods

to efficiently resolve complaints on short term and implement measures to avoid reoccurrence. Fabory requires to receive 8D reports in case of deviations on mechanical properties and upon request by Fabory also in case of dimensional or other deviations.

Product Quality Complaints, Rejections and quality level of 8D reports influence the Supplier Performance Rating.

### 3.6 Batch traceability

Fastener standards require batch traceability for most material property classes. Supplier will maintain a batch traceability system that assures a clear link between the supplier lot number on the delivered packaging labels, the raw material certificate, the inspection test results, the process parameters used e.g. in heat treatment, coating, hydrogen de-embrittlement treatment, whenever applicable for the supplied batches. Traceability information shall be available for at least 10 years + the running year.

Fabory might require to obtain such batch traceability information, for example documented in a inspection test report or certificate.

### 3.7 Audits by Fabory

Fabory reserves the right to perform a quality audit at the supplier's production plant and at their subcontractors for critical processes. Supplier will cooperate in such audits and will provide sufficient and reliable information related to his quality management system, upon request of the Fabory auditor.



## 4. Inbound logistics

By adhering to the operating procedures stated in this Supplier Manual Fabory aims to provide a flawless inbound logistics flow for its customers. Deviations detected in logistics lead to rework and incurred costs which shall be avoided.

Unless stated or agreed otherwise in writing by the Fabory procurement department, the suppliers shall deliver all products packed in the neutral corrugated carton box. No supplier information (name, address, logo, etc.) on package and label. By confirming PO, it means supplier will accept the Fabory Package & Label requirements

Within Fabory warehouses we have a high degree of automation. Many articles are transported using conveyors and automated cranes. This automated logistics process has specific requirements. It's a material characteristic whether a material is handled via this automated process; these materials are called "conveyables". The most important criterium for a material to be "conveyable" is that 2 or more sell packs need fit into a standardized box with inner dimensions 376 x 229 x 149 mm while not exceeding 25 kilograms.

### 4.1 Sell packs

The sell pack contains a pre-defined quantity (in Fabory PO) of products. Goods are preferably packed in corrugated carton boxes instead of plastic bags unless product characteristics make this impossible. For oily products, products should be packed in a plastic bag first and then put in the sell pack.

#### General sell pack

The Fastener Sell Pack label has the following requirements:

- The content of label: provided by Fabory directly after the PO in the "Label information file"
- The design of label (see images below). The **FABORY** logo will be provided to you.
- The size of the label: 66,7 x 46,0 mm
- The label borders and **FABORY** logo must be in blue (PMS 3005) and texts in black
- The text font must be Arial Bold, size 10
- All texts must be in English and information on the label must comply with the Fabory Label Information file
- The barcode is in "Code 128" and carries the Fabory part number
- The label must not be folded over edges

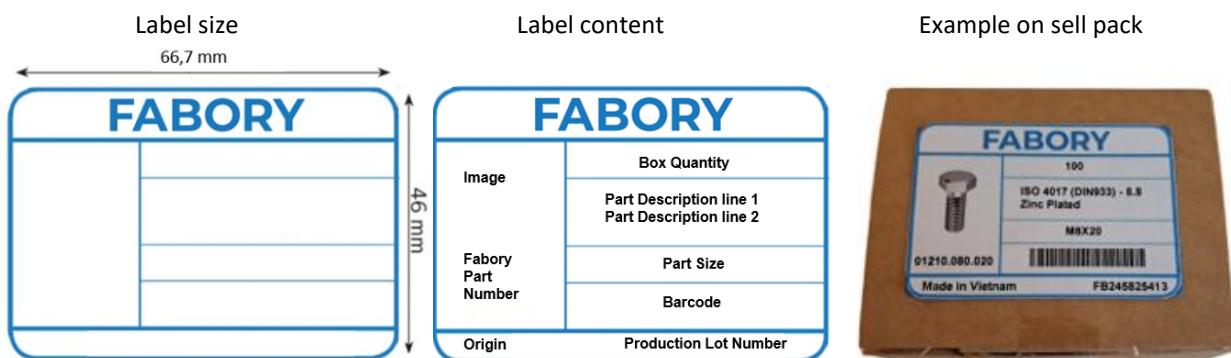

Fabory must approve alternatives to this. An alternative label must contain at least the following information.

- Article number (including barcode)
- Article description
- Item quantity
- Preferably a product image
- Preferably the Fabory article number

#### Products with shelf life

For items with shelf life, the remaining shelf life should be at least 180 days upon delivery unless agreed otherwise.

## Conveyable products

Sell packs should be matching the Fabory box size and carton quality (see table below). Which box you should use for which product will be communicated to you in the "Label information file", provided by Fabory along with the Purchase Order. Boxes should be closed using tape or glue and any oversized products, which cannot be packed with Fabory sell pack, should be packed with the supplier's sell pack. However, the supplier's sell pack should not exceed the height and length of the master pack (internal dimensions 376 x 229 x 149 mm). Further details can be found in Appendix C.

Box	Length (mm) (Outer size)	Width (mm) (Outer size)	Height (mm) (Outer size)	# Sell Packs per Master Pack	Minimal Technical Requirements	
					Minimal BST*	Minimal ECT**
A42	72	55	35	80	>400 Kpa	>2 KN/m
A43	72	55	48	60	>400 Kpa	>2 KN/m
A45	90	72	48	36	>400 Kpa	>2 KN/m
A46	120	72	48	27	>400 Kpa	>2 KN/m
A47	120	72	73	18	>400 Kpa	>2 KN/m
A48	180	110	48	12	>500 Kpa	>2,5 KN/m
A49	223	120	48	9	>700 Kpa	>3,5 KN/m
A50	180	110	73	8	>500 Kpa	>2,5 KN/m
A51	223	120	73	6	>500 Kpa	>2,5 KN/m
A53	180	105	145	4	>900 Kpa	>4 KN/m
A54	223	116	145	3	>900 Kpa	>4 KN/m
A55	223	176	145	2	>900 Kpa	>4 KN/m

\* BST = bursting strength test

\*\* ECT = edge crush test

## 4.2 Master pack

The master pack is the outer package, a carton or case (not a pallet), that the supplier uses to send the product to Fabory. The master pack contains in general multiple sell packs.

### General requirements

When goods are delivered to Fabory not palletized but as loose cartons, then these cartons also need to be numbered with the total number of boxes. See picture below.

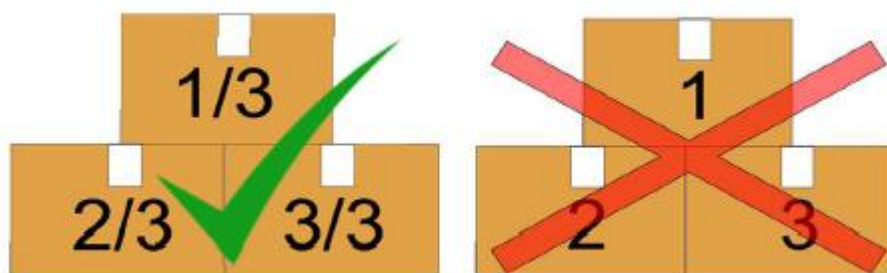

As much as possible one article and one supplier lot per master pack. When articles and/or supplier lots are mixed in a master pack then a sticker "MIX" should be applied. If applicable, please state the supplier lot on the outer carton. It is preferred to state the article number in the barcode. The contents should be listed on the outside.

- article (including barcode)
- number of sell packs
- quantity per sell pack
- total number of pieces in the master pack

## Non-conveyable & chemical products

Box weight is maximized on 25kg unless the weight of one item exceeds this.

The quality of the master pack box should be solid enough not to damage the goods during transport and handling. If filling material cannot be avoided, then please use paper or cardboard only. For fragile products please state FRAGILE and/or THIS SIDE UP on the master pack.

## Conveyable products

The weight of a master pack including contents is maximized on 25 KG. Preferably a master pack with internal dimensions 376 x 229 x 149 mm is used as this dimension is tailored for Fabory's automatic storage and retrieval system. See Appendix D for details. No padding material should be used in the master pack and if the article is packed in a plastic bag, then the master pack should be filled up not more than 70%.

## 4.3 Pallet

Goods should be delivered on undamaged official Euro pallets (EPAL), with a maximum weight of 1000 kilograms. Damaged pallets are considered one-way. Please make sure to load truck or container with pallet labels facing the door/opening of the truck.

### Pallet identification and -documentation

A packing list on the outside of the pallet in a docubag on top of each individual pallet needs to be applied. The pallet or consignment number should be stated on the packing list by barcode, in addition to the number. These barcodes will be matched against the EDI advance shipping notification received before arrival of the goods.

On this document, the country of origin has to be declared and for articles with a shelf life, stating the expiration date (not the production code!) for each supplier lot on the packing list is obligatory.

Certificates need to be delivered in advance of the shipment by emailing them to [quality.control@fabory.com](mailto:quality.control@fabory.com). For chemical materials, the Material Safety Data Sheets must be sent in advance to [technology@fabory.com](mailto:technology@fabory.com).

Delivery notes need to contain the following details:

- Fabory order number and order position
- Fabory article number
- Article description
- Delivery quantity
- Delivery note nr. and, possibly, consignment number
- Country of origin of goods
- Vendor lot number
- Best before date

### Pallet height and stacking

The maximum pallet loading height, including the pallet, is 120 cm unless the dimensions of the article exceed this. The consignment must be properly secured on the pallet using shrink wrap, nylon straps and/or wooden stacking edges. No self-fabricated wooden crates shall be used and never load above the wooden stacking edge. Wood packaging material (i.e. wooden crate and pallet) must be treated according measures as specified in ISPM 15, and display a mark as specified in Annex II of ISPM II.

Unmixed deliveries are required to avoid additional deconsolidation work. If, in exceptional cases, it is only possible to deliver a mixed pallet (different items or batches of the same item on one loading unit), then this must be clearly A4 marked with "MIX". Heavy boxes should be at the bottom of the pallet to ensure pallet stability.





## Threaded rods 1 meter

The weight of threaded rods also should be a maximum of 1,000 kilograms. Mix as few articles and/or supplier lots on one pallet as possible. When articles and/or supplier lots are mixed on a pallet, then they should be separated and identifiable as such. Pallet should be marked with MIX sticker.

Use iron brackets to keep the load on the pallet, see pictures below. The maximum pallet height should neither exceed 40 cm including the pallet nor the iron bars. Brackets should be bent inwards so that the upper side of the load does not protrude from the pallet.

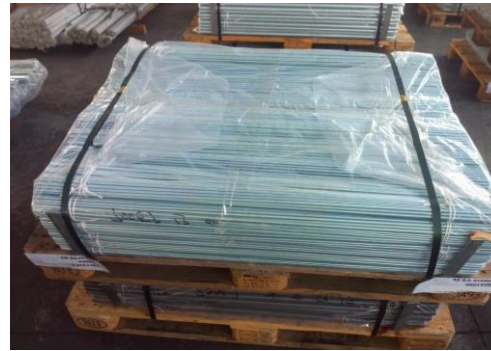

Rod ends should be coloured according to Fabory specification, see Appendix E. For blank steel, rods should be lightly oiled.

## Threaded rods 2- and 3 meters

On top of the requirements for 1-meter threaded rods a safe and efficient pallet solution should be selected by the supplier. Preferably use pallet brackets or clamps to secure the load on the pallet instead of a wooden crate. The pallet height is maximized on 40 centimeters including the pallet.

## 5. Transport

This section outlines the general rules that must be followed for all transport movements to our European plants. These rules are essential to ensure a reliable and successful delivery of your goods.

The load must be stowed and secured so that it cannot shift, that damage, falling over or falling off the vehicle is avoided, for example by using inflatable bags on the sides for sea containers. Any transportation damage resulting from incorrect packaging or loading done by the supplier will be invoiced to the supplier. Fabory will note obvious transport damage on the shipping documents at receipt of goods. Concealed transport damage can be reported seven days after receipt.

### 5.1 Physical delivery of goods

Warehouse	Unloading times
Fabory Central Warehouse Tilburg the Netherlands	Monday to Friday from 08:00 till 16:30 hrs
Fabory Mijdrecht the Netherlands	Monday to Friday from 08:30 till 16:30 hrs
Fabory Brno Czech Republic	Monday to Friday from 06:30 till 16:00 hrs
Fabory Chomutov Czech Republik	Monday to Friday from 06:30 till 15:00 hrs
Fabory Seixal Portugal	Monday to Friday from 08:00 till 17:30 hrs
Fabory Wednesbury United Kingdom	Monday to Friday from 08:30 till 17:00 hrs
Fabory Aartselaar Belgium	Monday to Thursday from 07:00 till 15:30 hrs Friday from 07:00 till 14:00 hrs
Imperial Fabory Logistics	Monday to Friday from 08:00 to 17:00 hrs

### 5.2 Preferential incoterms

Incoterms are agreed in negotiation. Fabory has its preferred incoterms depending on the mode of transport, such as road or sea and depending on the origin of the shipment. Air transportation is only used when the delivery date cannot be met after approval.

Origin	Mode	Incoterm
European Union (EU)	Road	EXW or DAP
Europe (non-EU)	Road	FCA or DAP
Intercontinental	Sea	FOB
Intercontinental	Air	FCA, CPT, DAP, or DDP

### 5.3 Collaboration guidelines

The points below describe important steps to ensure a smooth and efficient delivery of your products.

The relevant customs regulations and procedures for importing and exporting goods across borders need to be followed. The relevant transport and packing regulations and procedures for transporting goods need to be followed. Please collaborate with our logistic partners, details found in Appendix F, to create export or import documents, communicate goods readiness, and follow their loading instructions for your products. Please send the correct documents per details in Appendix G and H.

The pickup form and send it to us to confirm your products are ready. The Packing list should include:

- article numbers
- product description
- quantity
- net weight
- gross weight
- dimensions
- packaging type

Send us the Certificate of Origin and when applicable the Long-Term Declaration for goods supplied over a period of 1 or 2 years. When applicable, send us the EUR1 or variant, such as an ATR with the physical documents.

You can find the exact details, communication matrix, and instructions regarding these topics in the relevant sections or documents in Appendix I.

#### 5.4 Additional sea freight requirements

In the case of Full Container Loads (FCL) the supplier hands over the fully loaded container which has been sealed under the FOB incoterm under the supervision of our respective agent. The container will only be opened by Fabory at the end of its destination. The responsibility for loading the container and securing the goods lies with the supplier.

In the case of Less than Container Loads (LCL) the forwarder or agent from Fabory subsequently loads the freight in the container combining the shipment with goods destined for other parties as well. The container is opened at the port of destination and the different loads are unloaded and handled. There is more handling of the pallets compared to FCL shipments. Therefore, the supplier must communicate to the forwarder how freight will be secured in the container and follow general handling instructions.

The Certificate of Origin must be sent while sending the Bill of Lading when the cargo is ready to be shipped.

## 6. Compliance and ESH

### 6.1 General principles

#### Comply with the laws and regulations in each country in which the supplier operates

Where there are differences between the provisions of this Supplier Code of Conduct and national laws or other applicable standards, suppliers shall adhere to the higher or more stringent requirements.

#### Demonstrate and promote its commitment to responsible business practice in policies, decisions and activities

Supplier shall upon request by Fabory, provide evidence of its compliance with the obligations set out in this Supplier Code of Conduct.

#### Fair competition

Fabory respects and is committed to the rules governing free and fair competition and to comply with applicable antitrust and other laws regulating competition. Our suppliers shall equally commit to competing in a fair manner in compliance with all applicable competition laws and regulations.

When conducting business with Fabory, our suppliers shall deal fairly with all individuals and entities with whom they interact and shall not take advantage of anyone through manipulation, concealment, abuse of privileged information, misrepresentation of material facts, or any other unfair dealing or practice.

Our suppliers shall not engage in collusive binding, price fixing, price discrimination or other unfair trade practices in violation of applicable antitrust and other laws regulating competition.

#### Confidentiality

Our suppliers shall not disclose nor use for their own purposes of any other Fabory trade secrets, confidential information, knowledge, designs, data, skill, or any other information considered by Fabory as sensitive information.

Our suppliers shall respect the intellectual property rights of Fabory and of others, observe and respect all patents, trademarks, and copyrights, and comply with all requirements and terms of their use.

### 6.2 Anti-corruption

Suppliers that Fabory does business with must not use illegal payments, bribes, kickbacks or other questionable inducements to influence any business transaction. Fabory specifically prohibits bribery by any of its employees or agents. A practice that conflicts with this policy might be considered acceptable in a particular country, however it is not acceptable for Fabory.

### 6.3 Principles of human rights and social justice

Suppliers must support and respect the protection of internationally proclaimed human rights and make sure that they are not complicit in human rights abuses.

#### Non-discrimination

All employees of the supplier shall have equal opportunities based on competencies, experience and performance regardless of gender, race, religion, age, disability, sexual orientation, nationality, political opinion, union affiliation, social background or ethnic origin. All employees should be treated with respect. Discrimination, physical or verbal harassment, or any illegal threats are not tolerated.

#### Forced labour

Supplier will not engage in or support forced, bonded or compulsory labour, nor shall the Supplier require any form of deposit or confiscate identification papers from employees.

#### Child labour

Fabory respects the children's right to development and education. Suppliers must not engage in child labour. The supplier shall ensure that no employee is younger than the legally fixed age for employment. Minimum age is the age for completion of compulsory schooling, but not younger than 15 years or not younger than 14 years in those countries that are subject to the developing country exception to the ILO Convention 138.

The supplier should abide by the United Nations Convention on the Rights of the Child (1989) and comply with all relevant national and international laws, regulations and provisions applicable in their country of production or operations.

## Freedom of association

Suppliers must respect the right of employees to join any organized associations of their own choosing and to bargain collectively as permitted by local laws and regulations. Suppliers shall respect the recognized unions. The supplier should also equally respect an employee's right to refrain from joining a union.

## Working hours and compensation

Suppliers shall comply with applicable laws, agreements and industry standards on working hours and compensation.

## 6.4 Health and safety

Suppliers to Fabory shall safeguard a healthy and safe working environment for all employees, in accordance with international standards and national legislation. Where the supplier provides its employees with accommodation such facilities must as a minimum be clean, safe and meet the employees' basic needs.

A supplier must establish organizational structures and procedures for the effective management of health, safety and environmental risks. Appropriate information and training on health and safety should also be offered to the employees.

## 6.5 Environment

A supplier should take preventive measures in relation to environmental challenges, undertake initiatives to promote greater environmental responsibility and encourage the development and diffusion of environmentally friendly technologies. A suppliers' actions should be based on the relevant national and international laws, regulations and standards in respect to environment. Supplier shall minimize its environmental impact and continuously improve its environmental performance.

## 6.6 Material compliance & conflict minerals

At Fabory, we are determined to comply with regulatory and customer requirements regarding the prohibition and restriction of substances, including hazardous substances and conflict minerals. Therefore, suppliers shall ensure that the goods provided to Fabory are in compliance with requirements covered under the scope of all relevant environmental regulations. Suppliers shall perform sufficient efforts to avoid substances of very high concern (SVHC) and are obliged to inform Fabory in writing if such SVHC is present in the supplied products in excess of 0,1% (weight).

The Candidate List of Substances of Very High Concern (SVHC) is related to the REACH directive EC 1907/2006 and is regularly updated. The latest edition of the SVHC-list is available via the links underneath. Items that are ordered according to RoHS compliance legislation, shall supplementary comply with the latest edition of the RoHS directive 2015/863.

- REACH link: <https://echa.europa.eu/regulations/reach/understanding-reach>
- SVHC link: <https://echa.europa.eu/candidate-list-table>
- RoHS link: <https://eur-lex.europa.eu/legal-content/EN/TXT/PDF/?uri=CELEX:32015L0863&from=EN>

Supplier warrants that all the products and components provided to Fabory do not directly or indirectly contain Conflict Minerals, as defined by the United States Dodd Frank Act, Section 1502. Fabory requires manufacturing companies to identify and disclose the source of 3TG minerals (tin, tantalum, tungsten and gold) used in products supplied to Fabory upon request.

Finally Fabory expects its suppliers to provide Fabory in writing and as early as possible and before delivery of the products, valid documentation about:

- any permit requirements (for example Dual Use) applicable to products that are being delivered and result from the applicable Dutch, European (EU), American (USA) and Asia export, tariff and trade laws
- the Country of Origin of the products they supply to Fabory based on applicable export, tariff and trade laws



## 6.7 Auditing & reporting

Fabory has a culture of ethics and compliance. Fabory team members are trained on Ethics and Compliance annually. If a supplier is neglecting Fabory's request to comply to this Code of Conduct, or is refusing to provide a planning and proof of action to be in compliance with this Code of Conduct, Fabory may decide to stop any cooperation with the supplier."

## Appendices

### Appendix A: invoice data

ORDER PLACED FOR/LOCATION	PURCHASER ON THE INVOICE AND PACKING LIST	E-MAIL ADDRESS FOR E-INVOICE	VAT
Netherlands (NL)-CWT	FABORY NEDERLAND B.V. Laurent Janssensstraat 112 5048 AR TILBURG The Netherlands Tel: +31 13 5941234 Fax: +31 13 5941390	<a href="mailto:e-invoice_0100@fabory.com">e-invoice_0100@fabory.com</a>	NL004077684B01
Portugal (PT)	FABORY PORTUGAL, UNIPESSOAL, LDA Rua Rodrigo Sarmiento de Beires N.º18 2840-068, Aldeia de Paio Pires, Portugal Tel: +351 212135900 Fax: +351 212135929	<a href="mailto:e-invoice_1200@fabory.com">e-invoice_1200@fabory.com</a>	PT502684216
Czech Republic (CZ)	Fabory Czech s.r.o K Letisti 1825/1A 627 00, Slapanice u Brna, Czech Republic	<a href="mailto:e-invoice_1495@fabory.com">e-invoice_1495@fabory.com</a>	CZ25357425
Combori N.V.	Combori N.V. Blancefloerlaan 179A 2050 Antwerpen, Belgium	<a href="mailto:e-invoice_0500@fabory.com">e-invoice_0500@fabory.com</a>	BE0404936002
Fabory Centres Belgium N.V.	Fabory Centres Belgium N.V. Blancefloerlaan 179A 2050 Antwerpen, Belgium	<a href="mailto:e-invoice_0600@fabory.com">e-invoice_0600@fabory.com</a>	BE0430092258
Fabory France S.A.	SA Fabory France Chassieu park batiment A1 96 Avenue du Progrès 69680 Chassieu, France	<a href="mailto:e-invoice_1100@fabory.com">e-invoice_1100@fabory.com</a>	FR73458504438
Fabory UK Ltd.	Fabory UK Ltd Woden Road West Wednesbury, WS10 7SG, United Kingdom	<a href="mailto:e-invoice_1300@fabory.com">e-invoice_1300@fabory.com</a>	GB488315808
Fabory Slovakia s.r.o.	Fabory – Slovakia, s. r. o. Ludvíka Svobodu 2674/1 05801 Poprad, Slovensko	<a href="mailto:e-invoice_1500@fabory.com">e-invoice_1500@fabory.com</a>	SK2020015822
Fabory Kötőelem Kereskedelmi Kft.	Fabory Kötőelem Kereskedelmi Kft. Fáy utca 4 1139 Budapest, Hungary	<a href="mailto:e-invoice_1600@fabory.com">e-invoice_1600@fabory.com</a>	HU11756217
Fabory Poland Sp.z.o.o.	Fabory Poland Sp.z.o.o. Lutycka 93 60-478 Poznan, Poland	<a href="mailto:e-invoice_1700@fabory.com">e-invoice_1700@fabory.com</a>	PL9581295437
S.C. Fabory Srl. (Romania)	S.C. Fabory Srl. Str. Aurel Vlaicu 40 Brasov, 500178, Romania	<a href="mailto:e-invoice_1800@fabory.com">e-invoice_1800@fabory.com</a>	RO18915677
Fabory Spain SLU	Fabory Spain, S.L.U. Calle Velázquez 64, 4 Izquierda 28001 Madrid, España	<a href="mailto:e-invoice_2100@fabory.com">e-invoice_2100@fabory.com</a>	ESB86410339

## Appendix B: FOB /CIF shipping & down payment instructions

### 1. Shipment booking

All shipment bookings addressed to Fabory should be booked 14 days before the cargo ready date. Supplier can reach the agency according to the contact info below:

Fabory appoints Caroz to arrange shipments to **Fabory NL**. Supplier can reach the agency according to the contact info as mentioned in Appendix I. For shipments to **Fabory CZ**. Supplier can follow up with the shipment booking through the contact info below:

All Shippers FOB to Fabory CZ, please contact Transportation Operations Specialist in Fabory CZ

Tel: +420 548 427 116

Mail: [transportcee@fabory.com](mailto:transportcee@fabory.com)

### 2. Document Submission Procedure

#### 2.1 Consignee and Notified Party

You can find your consignee and notified party per Fabory's purchaser in Appendix G.

#### 2.2 Digital Invoice & Packing List and Key Elements

Within **2 working days after the cargo has been picked up** by the carrier, the digital invoice and packing list (Excel and PDF) should be provided. Make sure the Caroz Shipment number (S00.....) or shipper reference number is stated in the subject of the email and also on the documents.

Please send these documents to:

- If shipments to Fabory NL to the responsible Fabory Buyer with a copy to [corporatepurchasing@fabory.com](mailto:corporatepurchasing@fabory.com) and [Fabory@caroz.com](mailto:Fabory@caroz.com).
- If shipments to Fabory CZ to the responsible Fabory Buyer with a copy to [corporatepurchasing@fabory.com](mailto:corporatepurchasing@fabory.com) and [transportcee@fabory.com](mailto:transportcee@fabory.com).

For the invoice (to be provided in Excel and PDF), the below elements must be included:

- |  |                                     |
|--|-------------------------------------|
| - Seller & Purchaser   | - Material                          |
| - Invoice title  | - Total Quantity (pcs)              |
| - Invoice No   | - Country of Origin                 |
| - Invoice Date   | - Container#                        |
| - Bank Account number  | - Payment Term                      |
| - Incoterm- Port & Final Destination                               | - Unit Price (with currency type)   |
| - PO No  | - Total Amount (with currency type) |
| - Fabory Material (Article No)                                     | - HS code (show first 6 digits)     |
| - Product name and description (with DIN-Standard or ISO-standard) |                                     |

If the products are manufactured in Public Republican of China, then the invoice must contain the cooperating export producer declaration text.

For the packing list (to be provided in Excel and PDF), the below elements must be included:

- |  |                          |
|--|--------------------------|
| - Seller & Purchaser   | - Pieces per box         |
| - PO No  | - Quantity of containers |
| - Pallet number (each pallet should have one unique pallet number) | - Boxes per container    |
| - Fabory Material (Article No)                                     | - Net Weight (KG)        |
| - Carton Qty   | - Gross Weight (KG)      |
| - Lot number   | - Volume (m3)            |
| - Total Quantity (pcs)   | - Country of Origin      |

Please follow the instruction below when arrange shipment. Please keep copies of originals for 5 years.

### 2.3 Bill of Lading (B/L)

Within 2 working days after the supplier has received the Bill of Lading (B/L), but not later than 2 working days after the vessel departure, the digital B/L should be sent to:

- If shipments to Fabory NL to the responsible Fabory Buyer with a copy to [corporatepurchasing@fabory.com](mailto:corporatepurchasing@fabory.com) and [Fabory@caroz.com](mailto:Fabory@caroz.com).
- If shipments to Fabory CZ to the responsible Fabory Buyer with a copy to [corporatepurchasing@fabory.com](mailto:corporatepurchasing@fabory.com) and [transportcee@fabory.com](mailto:transportcee@fabory.com).

For the Bill of lading a Telex release is required and must be available at least 7 days before the arrival date of the vessel at the Port of arrival. For the suppliers who don't get Sea waybill or Telex Release the BL but get original bill of loading (OBL), please send all original shipping document to the address below for custom clearance within 7 days after sailing. If any demurrage occurred due to late original shipping documents to Fabory or Telex Release BL lately, it would be supplier's responsibility.

### 2.4 Certificate of Origin (COO)

For all the shipments to Fabory Europe, supplier must submit COO for payment approval since 1/1/2018.

- If shipments to Fabory NL please also send the digital document to the responsible Fabory Buyer with a copy to [corporatepurchasing@fabory.com](mailto:corporatepurchasing@fabory.com) and [Fabory@caroz.com](mailto:Fabory@caroz.com).
- If shipments to Fabory CZ please also send the digital document to the responsible Fabory Buyer with a copy to [corporatepurchasing@fabory.com](mailto:corporatepurchasing@fabory.com) and [transportcee@fabory.com](mailto:transportcee@fabory.com).

Country/Region	Document requirements
China	A regular certificate of origin (non-preferential) issued by origin Chamber of Commerce. A certificate of origin Form A will not be accepted.
Hong Kong	A regular certificate of origin (non-preferential) issued by origin Chamber of Commerce. A certificate of origin Form A will not be accepted.
Japan	A regular certificate of origin (non-preferential) issued by origin Chamber of Commerce.
Malaysia	A regular certificate of origin (non-preferential) issued by origin Chamber of Commerce.
Taiwan	A regular certificate of origin (non-preferential) issued by origin Chamber of Commerce.
Thailand	A regular certificate of origin (non-preferential) issued by origin Chamber of Commerce.
Canada	A regular certificate of origin (non-preferential) issued by origin Chamber of Commerce.
USA	A regular certificate of origin (non-preferential) issued by origin Chamber of Commerce.
Utd.Arab.Emir.	A regular certificate of origin (non-preferential) issued by origin Chamber of Commerce.
Turkey	A EUR.1 form issued by origin Chamber of Commerce.
Indonesia	A statement on origin as allowed under the REX system. Please ensure you have provided us with a copy of your REX registration. If you have not registered yourself yet as a Registered Exporter you can provide us with a certificate of origin Form A until December 2020
Philippines	A statement on origin as allowed under the REX system. Please ensure you have provided us with a copy of your REX registration. If you have not registered yourself yet as a Registered Exporter you can provide us with a certificate of origin Form A until December 2020
Vietnam	Starting from the 1 <sup>st</sup> of January 2023, Vietnam is not able to utilize the REX certificate. A valid certificate of origin EUR1, validated by Vietnamese Customs is required.
India	A statement on origin as allowed under the REX system. Please ensure you have provided us with a copy of your REX registration. If you have not registered yourself yet as a Registered Exporter you can provide us with a certificate of origin Form A until June 2018.
South Korea	A declaration on your invoice as set forth in the EU-Korea Free Trade Agreement. Please provide us with a copy of your customs authorization number for our records.

## 2.5 EN ISO 16228 F3.1 or EN 10204 3.1

For Fabory's orders a EN 10204 3.1 Certificate is required with delivery. Please send in PDF file to [quality.control@fabory.com](mailto:quality.control@fabory.com).

## 2.6 REACH (SVHC)

According to the European REACH legislation, Supplier is obliged to inform Fabory to in writing to [quality.control@fabory.com](mailto:quality.control@fabory.com) in case delivered items contain Substances of Very High Concern (SVHC) with more than 0,1% of the product weight. The Latest edition of SVHC-list can be found via: <https://echa.europa.eu/candidate-list-table>; for example if Lead (Pb) >0,1%.

## 3. Payment Process

### 3.1 Document Submission

Once Fabory has received the full digital documents mentioned below Fabory will initiate payment according to payment terms. Otherwise payment will not be arranged.

- Invoice ((Excel and PDF)
- Packing List (Excel and PDF)
- Bill of Lading
- Proof of origin

### 3.2 Special requests

- Communication requirements:
  - o Use Caroz Shipment number (S00...) for communication reference such as for the subject of the email, otherwise Fabory reserves the right of returning the email because we cannot match the documents with the correct shipment.
- Document submission:
  - o Name of Documents - Please name the series of documents (IV & PL & B/L) in one series No.  
*Example: Fabory 20180615 – IV & Fabory 20180615 – PL & Fabory 20180615 – B/L*
  - o Documents Sequence - If you submit files of multiple shipments in one mail, please attach the documents in sequence.
- For item description, below elements must be included for custom clearance:
  - o Material Brand.  
*Example: Steel, Stainless Steel, Brass etc.*
  - o Product Name (No abbreviation) includes dimension and Grade/Class.  
*Example: 3/4-10x3-1/2 Steel Grade 8 Hex Head Cap Screw (3/4-3.5 HCS is not allowed.)*
  - o Surface treatment.  
*Example: Plain, Zinc plating, passivation etc.*
- To make sure the package material meets Fabory's request, please show below statement (choose A or B according to the actual situation) on both invoice and packing list:
  - o A: All SWPM is treated by heat treatment or methyl bromide method, and marked in compliance with ISPM#15 to meet regulation on 7CFR 319.40-3(B)
  - o B: No SWPM is used in this shipment.

## 4. Original document delivery

All original documents must be available 7 days before the arrival date of the vessel at the Port of Arrival. If applicable send your original documents to Appendix G: consignee and notify parties – sea.

## Appendix C: sell pack drawings

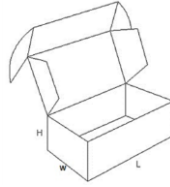

**Sell Pack: Size A42**

**Note:**  
 1. Material: F-F corrugated board, ECT $\geq$ 2KN/m, BST $\geq$ 400KPa  
 2. Outer dimension: 72\*55\*35mm  
 3. Fefco: 0427

Flute direction  
 Creasing line  
 Cutting line

Part Description		<b>FABORY</b>
Sell box - size 1		Date 20161101
Scale 1:1	Drawing No.	Version B

**Sell Pack: Size A43**

**Note:**  
 1. Material: F-F corrugated board, ECT $\geq$ 2KN/m, BST $\geq$ 400KPa  
 2. Outer dimension: 72\*55\*48mm  
 3. Fefco: 0427

Flute direction  
 Creasing line  
 Cutting line

Part Description		<b>FABORY</b>
Sell box - size 2		Date 20161101
Scale 1:1	Drawing No.	Version B

**Sell Pack: Size A45**

**Note:**  
 1. Material: F-F corrugated board, ECT $\geq$ 2KN/m, BST $\geq$ 400KPa  
 2. Outer dimension: 90\*72\*48mm  
 3. Fefco: 0427

Flute direction  
 Creasing line  
 Cutting line

Part Description		<b>FABORY</b>
Sell box - size 3		Date 20161101
Scale 1:1	Drawing No.	Version B

**Sell Pack: Size A46**

**Note:**  
 1. Material: F-F corrugated board, ECT $\geq$ 2KN/m, BST $\geq$ 400KPa  
 2. Outer dimension: 120\*72\*48mm  
 3. Fefco: 0427

Flute direction  
 Creasing line  
 Cutting line

Part Description		<b>FABORY</b>
Sell box - size 4		Date 20161101
Scale 1:1	Drawing No.	Version B

**Sell Pack: Size A47**

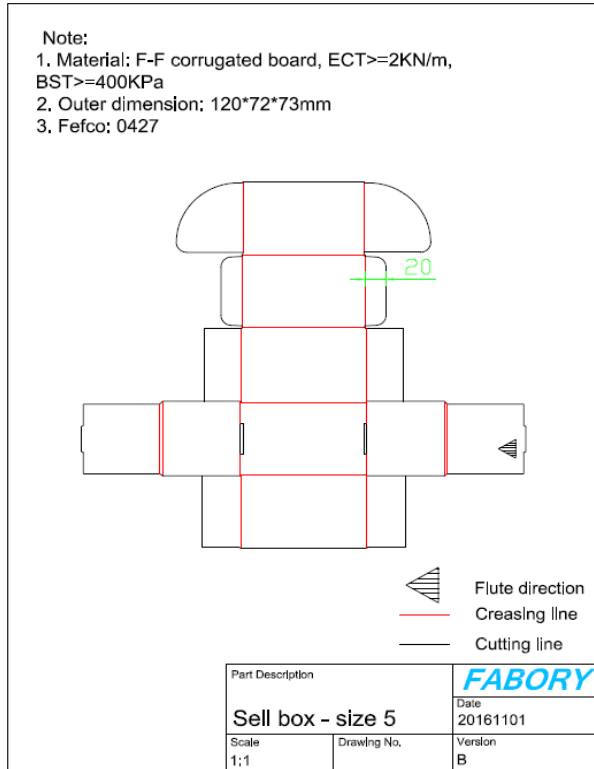

**Sell Pack: Size A48**

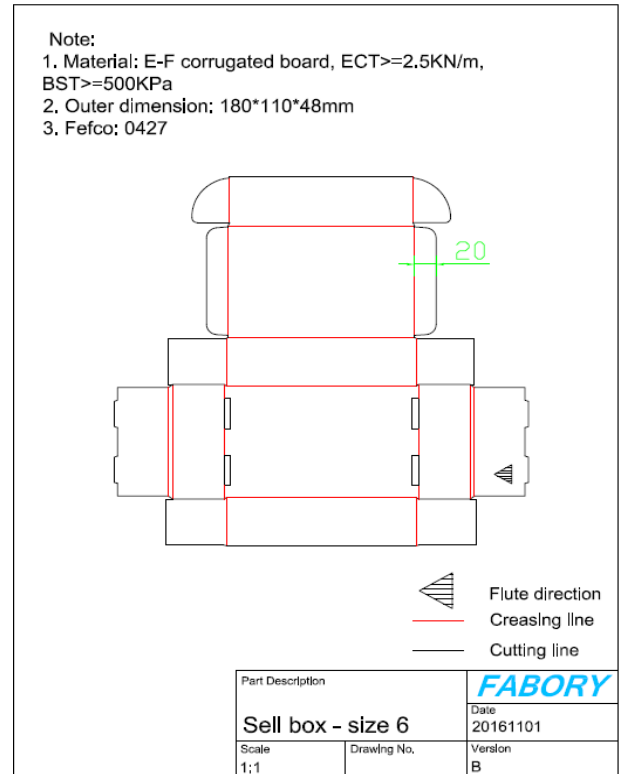

**Sell Pack: Size A49**

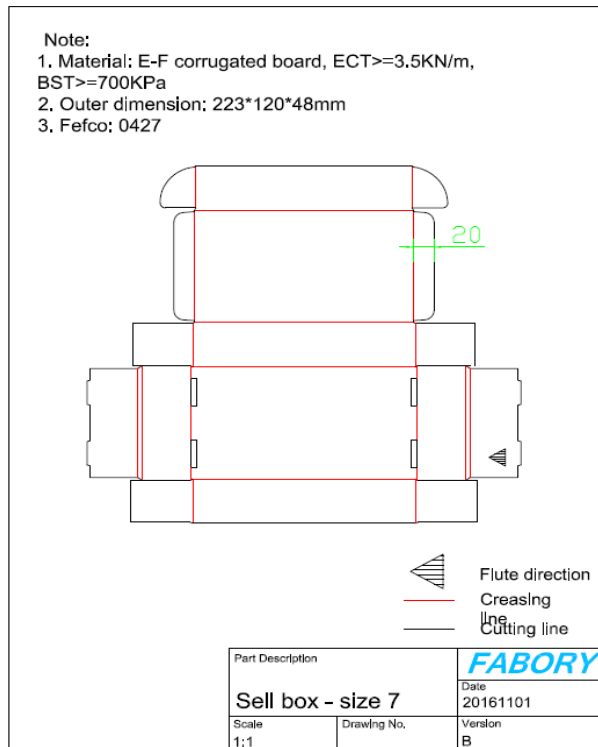

**Sell Pack: Size A50**

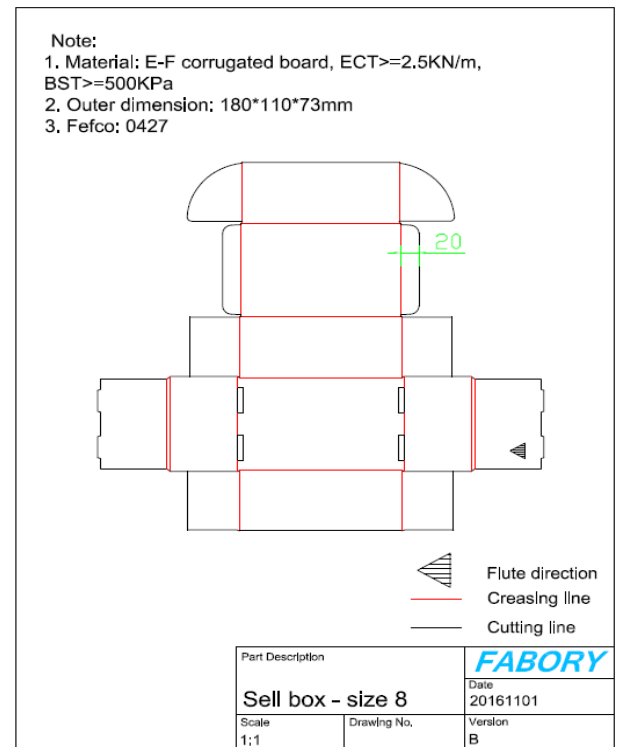

## Sell Pack: Size A51

**Note:**  
 1. Material: E-F corrugated board, ECT $\geq$ 2.5KN/m, BST $\geq$ 500KPa  
 2. Outer dimension: 223\*120\*73mm  
 3. Fefco: 0427

Flute direction  
 Creasing line  
 Cutting line

Part Description		<b>FABORY</b>
Sell box - size 9		Date 20161101
Scale 1:1	Drawing No.	Version B

## Sell Pack: Size A53

**Note:**  
 1. Material: E-F corrugated board, ECT $\geq$ 4KN/m, BST $\geq$ 900KPa  
 2. Outer dimension: 180\*105\*145mm  
 3. Fefco: 0427

Flute direction  
 Creasing line  
 Cutting line

Part Description		<b>FABORY</b>
Sell box - size 10		Date 20161101
Scale 1:1	Drawing No.	Version B

## Sell Pack: Size A54

**Note:**  
 1. Material: E-F corrugated board, ECT $\geq$ 4KN/m, BST $\geq$ 900KPa  
 2. Outer dimension: 223\*116\*145mm  
 3. Fefco: 0427

Flute direction  
 Creasing line  
 Cutting line

Part Description		<b>FABORY</b>
Sell box - size 11		Date 20161101
Scale 1:1	Drawing No.	Version B

## Sell Pack: Size A55

**Note:**  
 1. Material: E-F corrugated board, ECT $\geq$ 4KN/m, BST $\geq$ 900KPa  
 2. Outer dimension: 223\*176\*145mm  
 3. Fefco: 0427

Flute direction  
 Creasing line  
 Cutting line

Part Description		<b>FABORY</b>
Sell box - size 12		Date 20161101
Scale 1:1	Drawing No.	Version B



## Appendix D: conveyable master pack carton

### Type M02

Type	Length	Width	Height
M02	376mm(L)	229mm(B)	151mm(H)

**Type:** FEFCO 0201

**Quality:** 186K\*120B\*186K (K= Kraft paper; B= Corrugating medium, flute B)

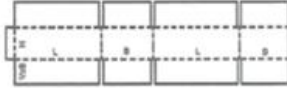

**0201**  
M/A

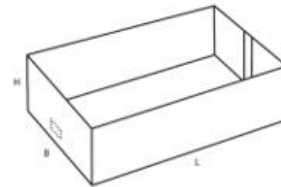

## Appendix E: colour table threaded rods

Colour codes threaded rods			
Class	Surface coating	FABORY Colourcode	RAL according DIN 976-1
4.8	Bright and zinc plated	Unpainted	
4.8	ISO metric hot dip galvanised	Light blue	
4.8	Oversized metric hot dip galvanised	Orange	
5.6	Steel	Chestnut brown	8015 <sup>a</sup>
5.8	Steel	Gentian blue	5010 <sup>a</sup>
8.8	Bright, zinc plated and yellow passivated	Traffic Yellow	1023 <sup>a</sup>
8.8	ISO metric hot dip galvanised	Stainelss steel colour 2116 <sup>*</sup>	
8.8	Oversized metric hot dip galvanised	Purple	
10.9	Steel	Oyster white	1013 <sup>a</sup>
12.9	Steel	Traffic black	9017 <sup>a</sup>
ASTM-B7	UNC & 8UN	Unpainted	
ASTM-B7	Metric	Unpainted	
RVS-A2	Stainless steel A2 metric	Traffic green	6024 <sup>a</sup>
RVS-A2	Stainless steel A4 metric	Flame red	3000 <sup>a</sup>

<sup>a</sup>Colour paint according RAL-840-HR

<sup>\*</sup>2116 is number of Rustolem stainless steel topcoating

## Appendix F: required transport documents

	EU		Non-EU		Intercontinental				
	TRUCK		TRUCK		SEA	AIRFREIGHT			
	EXW	DAP	FCA	DAP	FOB	FCA	CPT	DAP	DDP
Pick-up form (EXCEL)	i,ii,iii		i,ii,iii		iii,vi,	iii			
Digital Packing list (PDF)	i,ii,iii		i,ii,iii		iii,vi,				
Digital Packing list (EXCEL+PDF)			i,ii,iii	i,iii	iii,v,	iii,i	iii,v	iii,v	iii,v
Digital Invoice (EXCEL+PDF)			i,ii,iii	i,iii	iii,v,	iii,i	iii,v	iii,v	iii,v
Digital Bill of Lading					iii,v,				
Physical Packing list	ix	ix	ix	ix	ix	ix	ix	ix	ix
Physical Invoice			ix	ix	ix	ix	ix	ix	ix
Digital Certificate of Origin	iii	iii	iii	iii	iii, vi	iii,v	iii,v	iii,v	iii,v
Digital Certificate (Quality/Test)	viii	viii	viii	viii	viii	viii	viii	viii	viii
Physical Bill of Lading					vi				
Physical Certificate of Origin			iv	iv	vi	iv	iv	iv	iv
EUR 1 or other variant such as ATR			iv	iv	vi	iv	iv	iv	iv

i. transport*	v. See Appendix H, AIR notify	
ii. for NL, ASN, else transport*	vi. See Appendix G, SEA notify	
iii. your procurement contact, found on your Order Confirmation	vii. for NL/BE see Appendix I, else transport*	
iv. consignee	viii. <a href="mailto:quality.control@fabory.com">quality.control@fabory.com</a>	
	ix. attached on physical shipment	
Department	Country	Contact details
Transport*	NL	<a href="mailto:transport@fabory.com">transport@fabory.com</a>
	PT	<a href="mailto:procurement.iberia@fabory.com">procurement.iberia@fabory.com</a>
	BE	<a href="mailto:transport.aartselaar@fabory.com">transport.aartselaar@fabory.com</a>
	GB	<a href="mailto:scott.hayfield@fabory.com">scott.hayfield@fabory.com</a>
	CZ	<a href="mailto:transport.cee@fabory.com">transport.cee@fabory.com</a>

## Appendix G: consignee and notify parties - sea

ORDER PLACED FOR	PURCHASER ON THE INVOICE AND PACKING LIST/ CONSIGNEE ON THE B/L	NOTIFY PARTY / NOTIFY PART ON THE B/L
Netherlands (NL)	<b>FABORY NEDERLAND B.V.</b> Laurent Janssensstraat 112 5048 AR TILBURG The Netherlands Tel: +31 13 5941234	<b>Caroz B.V.</b> Jan Tinbergenstraat 12 5928 SE Venlo the Netherlands Tel: +31 (0) 77-3241220 <a href="mailto:fabory@caroz.com">fabory@caroz.com</a>
Belgium (BE)	<b>FABORY BELGIUM N.V.</b> Blancefloerlaan 179A 2050 Antwerpen Belgium Tel: +32 5045 0170	
Great Britain (GB)	<b>FABORY UK</b> Woden Rd W Wednesbury WS10 7SG United Kingdom	<b>NTG</b> Empire Ind Park, Brickyard Road Aldridge, Walsall, WS9 8UY United Kingdom
Czech Republic (CZ)	<b>FABORY Czech s.r.o.</b> K Letisti 1825/1a 627 00 Slapanice Czech Republic	<b>FABORY Czech s.r.o.</b> K Letisti 1825/1a 627 00 Slapanice Czech Republic

## Appendix H: consignee and notify parties - air

ORDER PLACED FOR	PURCHASER ON THE INVOICE AND PACKING LIST/ CONSIGNEE ON THE B/L	NOTIFY PARTY / NOTIFY PART ON THE B/L
Netherlands (NL)	<b>FABORY NEDERLAND B.V.</b> Laurent Janssensstraat 112 5048 AR TILBURG The Netherlands Tel: +31 13 5941234	<b>Rhenus Air &amp; Ocean B.V.</b> Folkstoneweg 202 1118 LN Schiphol The Netherlands Tel: +31 20 316 5555 <a href="mailto:customersupportimport.schiphol@nl.rhenus.com">customersupportimport.schiphol@nl.rhenus.com</a>
Belgium (BE)	<b>FABORY BELGIUM N.V.</b> Blancefloerlaan 179A 2050 Antwerpen Belgium Tel: +32 5045 0170	<b>Rhenus Air Belgium</b> NV Bedrijvenzone Machelen Cargo 741 1831 Machelen Belgium Tel +32 2 752 90 20
Great Britain (GB)	<b>FABORY UK</b> Woden Rd W Wednesbury WS10 7SG United Kingdom	<b>NTG</b> Empire Ind Park, Brickyard Road Aldridge, Walsall, WS9 8UY United Kingdom
Czech Republic (CZ)	<b>FABORY Czech s.r.o.</b> K Letisti 1825/1a 627 00 Slapanice Czech Republic	<b>FABORY Czech s.r.o.</b> K Letisti 1825/1a 627 00 Slapanice Czech Republic

## Appendix I: CAROZ' agents

Incoterm + origin	Agent	Contact person	Telephone number
FOB Shanghai / Ningbo / East & Central China	Caroz+ (Shanghai)	CarozPlus/Kelly Zhou <a href="mailto:zhou.kelly@carozplus.com">zhou.kelly@carozplus.com</a> CarozPlus/Jackie Cao <a href="mailto:cao.jackie@carozplus.com">cao.jackie@carozplus.com</a>	+852 632 31080
FOB Qingdao / Tianjin / North China	Caroz+ Qingdao Branch	Ms Belinda Li <a href="mailto:li.belinda@carozplus.com">li.belinda@carozplus.com</a> Ms Jessie Deng <a href="mailto:deng.jessie@carozplus.com">deng.jessie@carozplus.com</a>	+86 532 85861970
FOB Shenzhen / Xiamen / South China	Caroz+ Shenzhen Branch	Mr Tony Lau ( <a href="mailto:lau.tony@carozplus.com">lau.tony@carozplus.com</a> Ms Ada Chen <a href="mailto:chen.ada@carozplus.com">chen.ada@carozplus.com</a>	+86 755 22200426
FOB India	APG Logistics Pvt. Ltd.	<a href="mailto:docmum@apglogistics.com">docmum@apglogistics.com</a> Rajesh ( <a href="mailto:rk@apglogistics.com">rk@apglogistics.com</a> ) <a href="mailto:sundari@apglogistics.com">sundari@apglogistics.com</a>	+91 984 002 4561
FOB Indonesia	NS North Star Logistics, PT	<a href="mailto:andy@nslogistics.sg">andy@nslogistics.sg</a>	+62 817 0811155
FOB Malaysia	ACS Logistics (m) SDN BHD	<a href="mailto:export@acslogistics.com.my">export@acslogistics.com.my</a>	+60 425 00486
FOB Philippines	Wingspeed Shipping Corp	<a href="mailto:sales.alc@asialinkcargo.com.ph">sales.alc@asialinkcargo.com.ph</a>	+63 282 04475
FOB Singapore	NS North Star Logistics, PT	<a href="mailto:andy@nslogistics.sg">andy@nslogistics.sg</a>	+62 817 0811155
FOB South Korea	TGL Co. Ltd.	<a href="mailto:tgl@tgl-intl.com">tgl@tgl-intl.com</a>	+82 269 595087
FOB Taiwan	Coop Freight Logistics Ltd.	<a href="mailto:koko@cooptwn.com.tw">koko@cooptwn.com.tw</a>	+886 225 062000
FOB Thailand	Handle Inter Freight Logistics CO Ltd.	<a href="mailto:boonsuang@handleinterfreight.com">boonsuang@handleinterfreight.com</a>	+66 225 35995
FOB Vietnam	T&M Forwarding Ltd.	<a href="mailto:Thuy.dt@tmforwarding.com">Thuy.dt@tmforwarding.com</a> <a href="mailto:Geert.v.doorslaer@tmforwarding.com">Geert.v.doorslaer@tmforwarding.com</a>	+84 903 802831

# FABORY



[www.fabory.com](http://www.fabory.com)